

ZGI422X The Most Durable CCTV Camera

Outdoor Color IR Camera

INNEKT
Innovative Technology

- Stylish aluminum alloy housing design for outdoor usage
- SONY Super HAD CCD II with color 420 TV Lines
- Wide input voltage with internal regulator (DC 9-20V)
- IR Reflection free with double glass window design
- High efficiency low loss 850nm 30deg., 20 Metre
- Constant current circuit for long life IR LED
- High definition fixed iris 3.6 or 6.0 mm board lens
- IP67 Waterproof with outstanding durability
- Internal cable wiring with 3 axis bracket
- FCC , RoHS , CE Certified

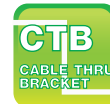

Dimensions (unit : mm)

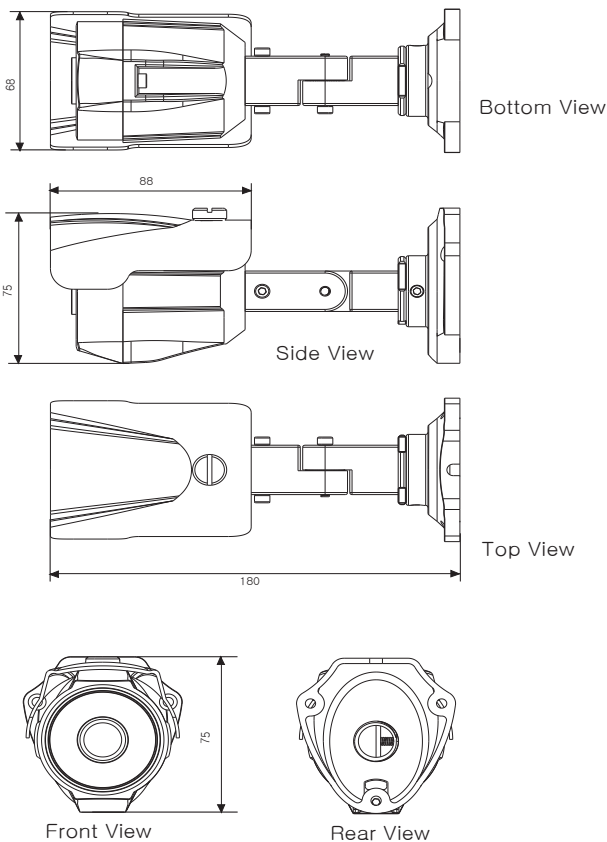

Specification

Model	ZGI422X
Signal System	PAL
Image Sensor	1/3" Sony Super HAD CCD II
Scanning System	2:1 Interlaced
Scanning Frequency	H: 15.625 KHz, V: 50 Hz
Total Pixels	537(H) x 597(V)
Effective Pixels	500(H) x 582(V)
Resolution	420TV Line
Electronic Shutter Control	1/50 - 1/100,000 sec automatic
S/N ratio	More than 48 dB (AGC Off)
Sensitivity	0 Lux (IR LED On)
Gamma correction	r = 0.45
Special function	Auto.Color-B/W switching
White balance	Auto.2500°K - 9500°K
Gain control	Auto. 4dB - 30dB
Synchronize System	Internal
Video Output	1 Vp-p 75 ohm Composite
Lens	Fixed lens at F2.0 f3.6mm(92°) / f6.0mm (53°)
Day / Night	Digital Day / Night
IR LED	850nm(30°) x 28 units, up to 20 M
IR LED Operation	On (1Lux) / Off (1Lux)
IP Rating	IP67 Waterproof
Power Supply	DC12V
Operating current	300mA w/regulated power in
Operating Temperature	14°F ~ 122°F (-10°C ~ +50°C)
Storage Temperature	-4°F ~ 140°F (-20°C ~ +60°C)
Dimension(mm)	68(W) x 75(H) x 88(D)
Weight(Approx.g)	580g

FC RoHS CE

www.innekt.com